

## QUANTIFICATION CURVES FOR MICA/SMECTITE INTERSTRATIFICATIONS BY X-RAY POWDER DIFFRACTION

KATSUTOSHI TOMITA,<sup>1</sup> HIDEWO TAKAHASHI,<sup>2</sup> AND TAKASHI WATANABE<sup>3</sup>

<sup>1</sup> Institute of Earth Sciences, Faculty of Science, Kagoshima University  
Kagoshima 890, Japan

<sup>2</sup> Department of Geology, Faculty of Education, Kagoshima University  
Kagoshima 890, Japan

<sup>3</sup> Institute of Geoscience, Faculty of Natural Science  
Joetsu University of Education, Joetsu, Niigata Prefecture, Japan

**Abstract**—X-ray powder diffraction (XRD) patterns for many interstratified mica/glycolated smectites were calculated by changing combinations of probabilities and transition probabilities of two-component layers. Three basal XRD reflections,  $5.1^{\circ}$ – $7.6^{\circ}2\theta$  ( $p_1$ ),  $8.9^{\circ}$ – $10.2^{\circ}2\theta$  ( $p_2$ ), and  $16.1^{\circ}$ – $17.2^{\circ}2\theta$  ( $p_3$ ) were selected for the quantification curves. A distinct relationship exists between  $\Delta 2\theta_1$  ( $p_2 - p_1$ ) and  $\Delta 2\theta_2$  ( $p_3 - p_2$ ) which shows systematic changes with expandability at constant Reichweite values. The calculated values were plotted with  $\Delta 2\theta_1$  and  $\Delta 2\theta_2$  as the axes of coordinates, and quantification curves were calculated. The components and stacking parameters of mica/smectites were estimated easily using this diagram. Probabilities of existence of component layers and their transition probabilities for Reichweite ( $R=0$ ) and ( $R=1$ ) structures, and special cases of  $R=2$  and  $R=3$  structures were obtained.

**Key Words**—Ethylene glycol, Interstratification, Mica/smectite, Reichweite structures, X-ray powder diffraction.

要旨—ウンモノスメクタイト混合層鉱物について、ウンモ層とエチレングリコール処理したスメクタイト層の存在確率とこれらの層の継続確率をいろいろ変え、多くの混合層構造についてX線粉末回折曲線を計算した。そして、 $5.1 - 7.6^{\circ}2\theta$  ( $p_1$ )、 $8.9 - 10.2^{\circ}2\theta$  ( $p_2$ ) と  $16.1 - 17.2^{\circ}2\theta$  ( $p_3$ ) に現れる3つの底面反射を構造決定図作成のために使用した。 $\Delta 2\theta_1$  ( $p_2 - p_1$ ) と  $\Delta 2\theta_2$  ( $p_3 - p_2$ ) の間には1つの明瞭な関係がみとめられ、それはReichweiteの値が同一の場合には、膨潤層の存在確率の変化に対して規則正しい変化を示した。この関係を使って、計算した  $\Delta 2\theta_1$  と  $\Delta 2\theta_2$  の値を横軸と縦軸にそれぞれとり、混合層構造を決定する図を作成した。この図を使うことによってウンモ層とスメクタイト層の存在確率および継続確率を容易に決定できる。本論文では、Reichweite ( $R=0$ ) と ( $R=1$ ) の全ての場合と、 $R=2$  と  $R=3$  の特別な場合に適用できる図を示した。

### INTRODUCTION

Many papers have been published on the calculation of X-ray powder diffraction (XRD) patterns of interstratified laminar systems. Méring (1949) presented simplified methods for the analysis of interstratified structures; MacEwan (1958) and Reynolds (1967) were able to correct the frequency terms,  $\sigma$ , into easily computed groups for different types of random interstratification; and Reynolds and Hower (1970) calculated patterns for ordered structures. Kakinoki and Komura (1952, 1954a, 1954b, 1965) showed how matrix methods can be used to obtain XRD profiles of interstratified structures that contain any number of compo-

nents. Allegra (1964) showed that the order of the matrices of the intensity equation can be reduced by introducing displacement vectors. Allegra's equation is similar to that of Kakinoki and Komura (1965). A comprehensive summary of the theoretical treatment of XRD for interstratified structures was given by Reynolds (1980). Sato (1969, 1973), Sato *et al.* (1965), Cradwick (1975), Drits and Sakharov (1976), and Watanabe (1981) applied the equation of Kakinoki and Komura (1954a, 1954b, 1965) for interstratified minerals and tried to quantify their interstratifications. Tomita and Takahashi (1985) derived XRD quantification curves for mica/smectite and chlorite/smectite

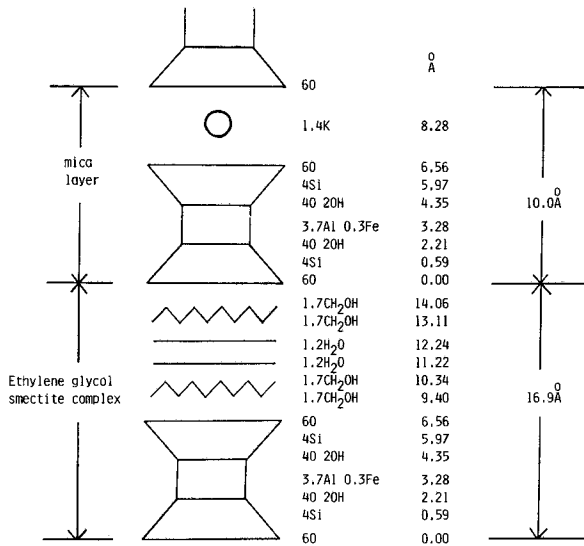

Figure 1. Model of mica and glycolated smectite layers used in calculation of X-ray powder diffraction patterns.

interstratifications using the equation of Kakinoki and Komura (1965).

Środoń (1980) prepared several graphs for the precise identification of illite/smectite interstratifications. We have prepared a diagram to determine the degree of interstratification in mixed-layer mica/smectites. Reynolds (1980), Środoń (1980), and Watanabe (1981) provided techniques for measuring layer ratios and for estimating the degree of ordering, but junction probabilities cannot be measured using their approach; such measurements are the goal of this paper. The method of Tomita and Takahashi (1985) can also be used to determine the layer ratios, degree of ordering, and junction probabilities in mixed-layer mica/smectites, but the present method is simpler, and if many interstratified minerals are plotted on the graph, the degrees of ordering for such minerals can easily be compared with each other. For the cases of Reichweite  $R=2$  and  $R=3$ , only the curves of 0.0 (transition probability of a smectite layer to a smectite layer is 0.0) have been shown. It was impossible and useless to discriminate the curves of  $P_{SS}$  for 0.1, 0.2, and 0.3 from the curve of 0.0 due to their close similarities.

**PREPARATION OF DETERMINATION CURVES**

XRD profiles of interstratified structures were calculated using the equation of Kakinoki and Komura (1965). The integrated intensity and the intensity maximum positions were calculated by an electronic computer using a slightly modified program from Takahashi (1982). Although uncertainties exist in the Lorentz factor at very low values of  $2\theta$  (Reynolds, 1983), a Lorentz-polarization factor for single crystals was used in the calculations. A value of 20 was used for the number of layers, in order to diminish ghost peaks

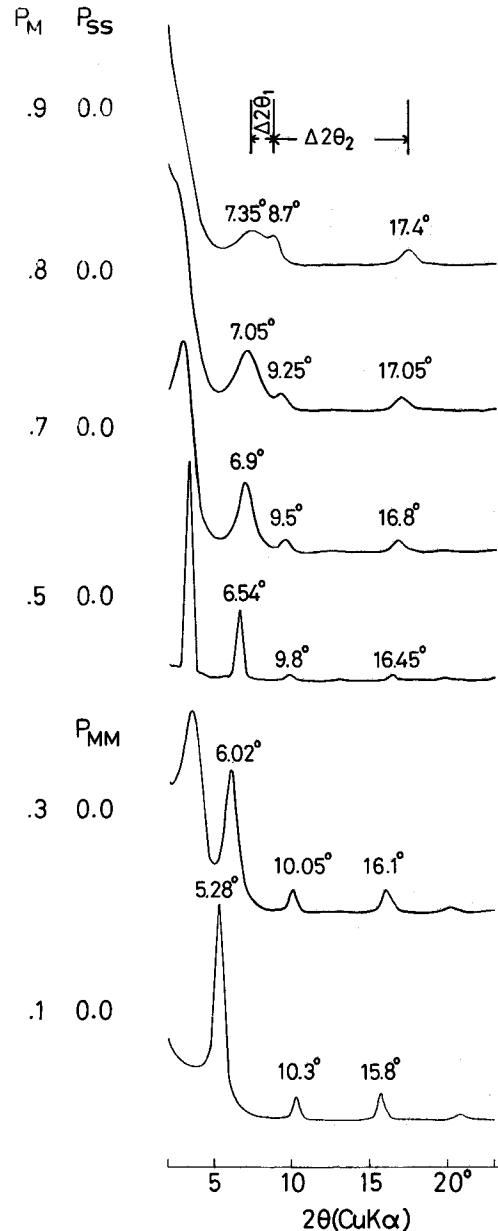

Figure 2. Calculated X-ray powder diffraction patterns for various interstratified structures.  $P_M$  is probability of existence of mica layer.  $P_{SS}$  is probability that a smectite layer succeeds a smectite layer given that the first layer is a smectite layer.  $P_{MM}$  is similarly defined.

which are common at low  $2\theta$  values if a small number of layers is used (Sato, 1973). The calculation of XRD patterns for interstratified structures was based on the model shown in Figure 1. A value of 16.9 Å was used for the ethylene glycolated smectite layer, as has been used by previous workers (Reynolds, 1980), although Środoń (1980) reported a range of 16.6–17.2 Å for glycolated smectites. Calculations were carried out for Reichweite values of  $R=0$  and  $R=1$  and for the special

cases of  $R=2$  and  $R=3$ . Three basal XRD reflections (a peak ( $p_1$ ) at  $5.1^\circ$ – $7.6^\circ 2\theta$ , a peak ( $p_2$ ) at  $8.9^\circ$ – $10.2^\circ 2\theta$ , and a peak ( $p_3$ ) at  $16.1^\circ$ – $17.2^\circ 2\theta$  ( $\text{CuK}\alpha$  radiation) after ethylene glycol treatment) were selected for the quantification curves. These three peaks are relatively strong and sensitive to the variation of the degree of ordering. The angular differences are represented as  $\Delta 2\theta_1 = p_2 - p_1$  and  $\Delta 2\theta_2 = p_3 - p_2$ . A distinct relationship exists between  $\Delta 2\theta_1$  and  $\Delta 2\theta_2$  that changes systematically with expandability at constant Reichweite values. The changes in calculated XRD patterns of some interstratified smectites are shown in Figures 2 and 3. Figure 2 shows the changes in calculated XRD patterns of fully ordered interstratifications. In Figure 2,  $P_M$  indicates the probability of the existence of a mica layer and  $P_{SS}$  indicates the probability that a smectite layer succeeds a smectite layer, assuming that the first layer is smectite.  $P_{MM}$  is similarly defined. Figure 3 shows the changes in calculated XRD patterns of some interstratified structures having 65% mica layers and different  $P_{SS}$  values. The calculated  $\Delta 2\theta_1$  and  $\Delta 2\theta_2$  values were plotted using  $\Delta 2\theta_1$  and  $\Delta 2\theta_2$  as the axes, and quantification curves were constructed (Figure 4). The numeral 0.0 in Figure 4 indicates that the transition probability of a smectite layer to a smectite layer is 0.0 if the proportion of mica layers is more than that of smectite layers (or, the transition probability of mica layer to mica layer is 0.0 if smectite layers are more abundant than mica layers). The other numerals, such as 0.1, 0.2, and 0.3 in Figure 4, are similarly defined.

The dotted line in Figure 4 indicates a random structure (Reichweite  $R=0$ ).

#### APPLICATION OF QUANTIFICATION CURVES TO NATURAL MINERALS

The Two Medicine and Kinnekulle A-2 samples investigated by Hower and Mowatt (1966) were selected as examples of the practical application of this method (Figure 5). The Two Medicine sample showed XRD reflections at  $13.4$  ( $6.6^\circ 2\theta$ ),  $9.5$  ( $9.31^\circ 2\theta$ ), and  $5.3$  Å ( $16.72^\circ 2\theta$ ). The  $\Delta 2\theta_1$  value for this specimen is  $2.71^\circ$  ( $9.31^\circ - 6.6^\circ$ ), and the  $\Delta 2\theta_2$  value is  $7.41^\circ$  ( $16.72^\circ - 9.31^\circ$ ). The values of  $\Delta 2\theta_1$  and  $\Delta 2\theta_2$  of this specimen are plotted in Figure 4 as A.  $P_M$  (the probability of existence of mica layer) can easily be seen to be .72 (72%), and  $P_{SS}$  (the probability that a smectite layer succeeds a smectite layer, given that the first layer is a smectite layer) can be seen to be .24 from the diagram. All remaining probabilities and junction probabilities for nearest-neighbor ordering can be obtained from these data and the statistical relations.

The statistics for mixed-layering are exemplified by an interstratified mica/smectite (M/S).  $P_M$  is defined as the frequency of occurrence of a mica layer,  $P_S$  is the frequency of smectite layers, and  $P_M + P_S = 1$ .  $P_{MS}$  is the probability that a smectite layer succeeds a mica

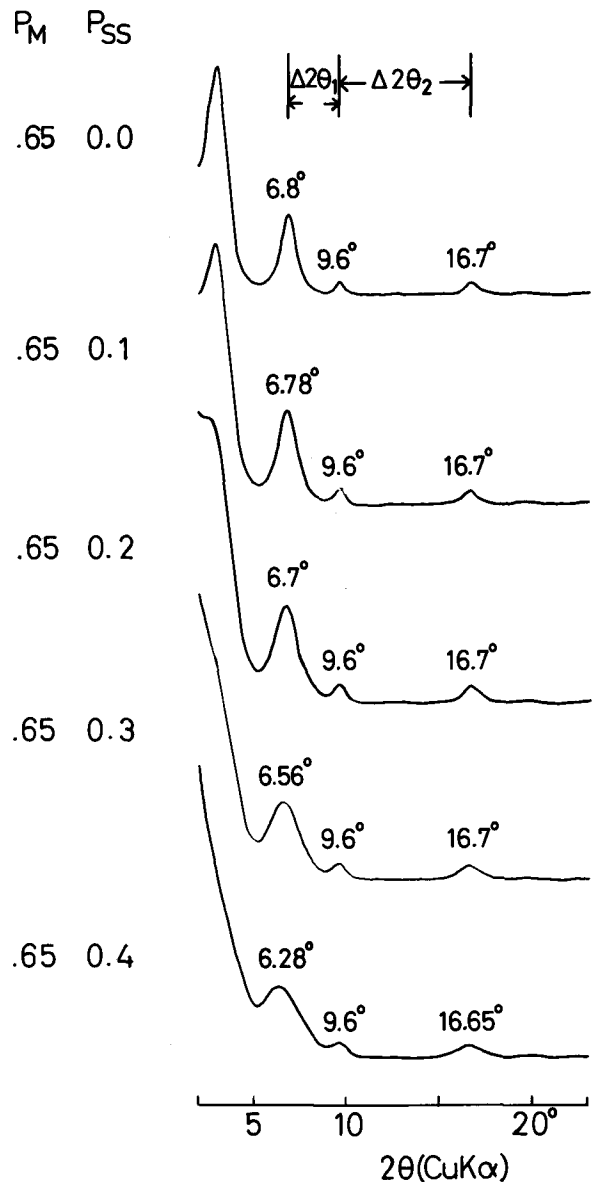

Figure 3. Calculated X-ray powder diffraction patterns for various interstratified structures having 65% mica layers.  $P_M$  is probability of existence of a mica layer.  $P_{SS}$  is probability that a smectite layer succeeds a smectite layer, given that the first layer is a smectite layer.

layer, given that the first layer is mica layer, and  $P_{MM}$ ,  $P_{SS}$ , and  $P_{SM}$  are similarly defined. Thus:

$$P_{MM} + P_{MS} = 1,$$

$$P_{SM} + P_{SS} = 1,$$

and

$$P_S P_{SM} = P_M P_{MS}.$$

Thus,  $P_M = .72$ ,  $P_S$  (the probability of the existence of a smectite layer) = .28,  $P_{MM} = .704$ ,  $P_{MS} = .296$ ,  $P_{SM} = .76$ , and  $P_{SS} = .24$  are obtained for this specimen, where M is a mica layer and S is a smectite layer.

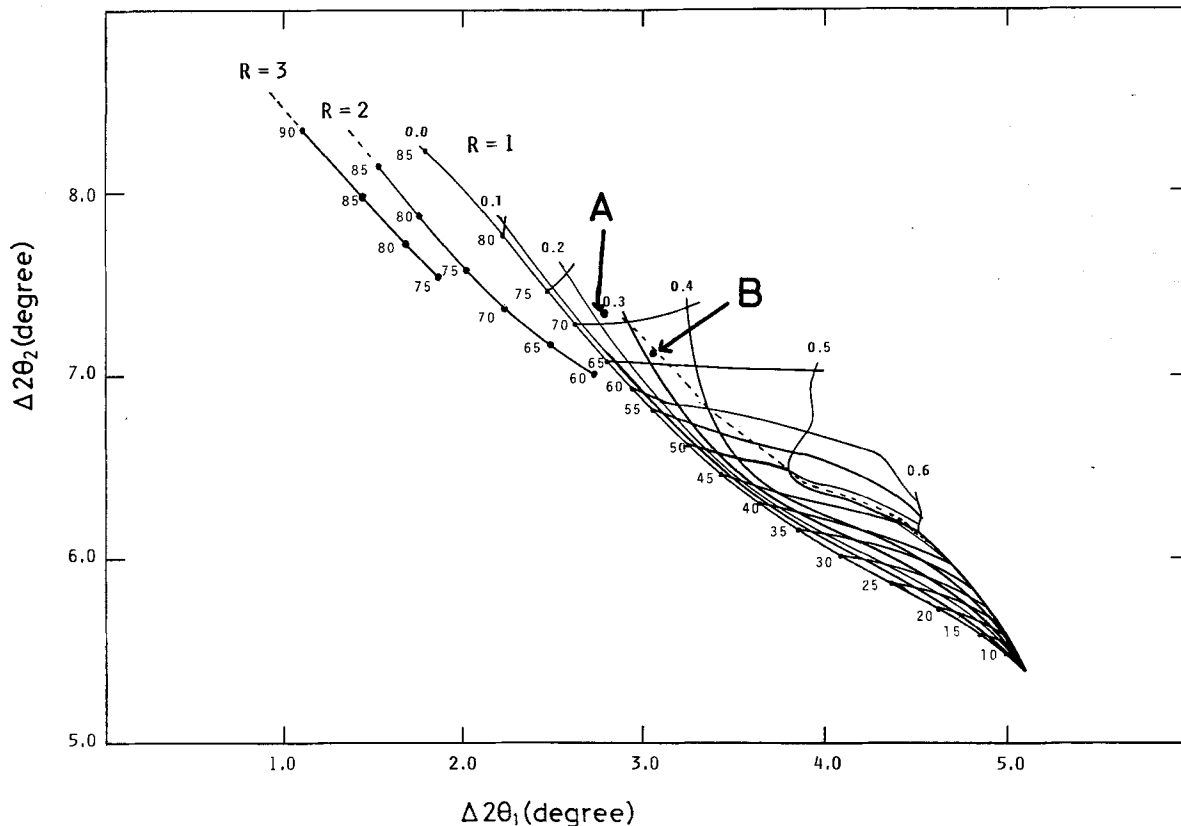

Figure 4. Diagram for quantification of mica/glycolated-smectite interstratifications. Dotted line indicates random structure ( $R=0$ ). A: Two Medicine, Wyoming. B: Kinnkulle A-2, Sweden.

The Kinnkulle A-2 sample showed XRD reflections at 13.9 ( $6.36^\circ 2\theta$ ), 9.4 ( $9.41^\circ 2\theta$ ), and 5.37 Å ( $16.5^\circ 2\theta$ ). In the same way as was described for the Two Medicine sample, values of  $\Delta 2\theta_1$  and  $\Delta 2\theta_2$  were obtained as 3.05° and 7.09°, respectively, and plotted as B in Figure 4. From the diagram  $P_M = .67$  and  $P_{SS} = .32$ . From these values,  $P_S = .33$ ,  $P_{MS} = .335$ ,  $P_{MM} = .665$ , and  $P_{SM} = .68$  were obtained.

The experimental and calculated XRD patterns of the Two Medicine and Kinnkulle A-2 samples are shown in Figure 5. The experimental data were obtained from Figure 2 of Hower and Mowatt (1966). Agreement between observed and calculated XRD patterns is fairly good. Differences in intensity are probably due to the differences of chemical compositions and/or preferred orientations within the samples.

#### DISCUSSION

The layer sequences of M/S were easily determined using the diagram presented in this study. This diagram is useful for the rapid quantification of layer sequences of such interstratifications. Differences in chemical compositions of elementary layers of interstratified minerals did not influence the determination of interstratification using this diagram. Chemical composi-

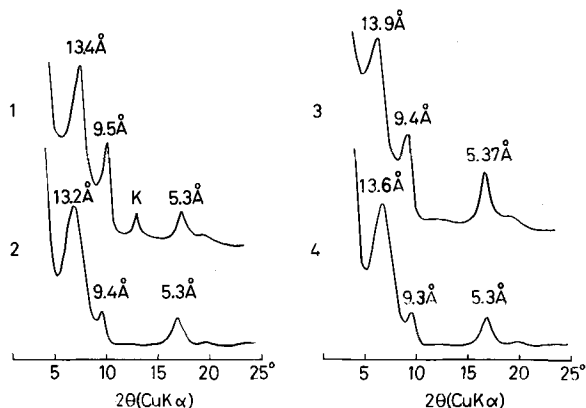

Figure 5. Comparison of experimental and calculated X-ray powder diffraction patterns of ethylene glycol-treated interstratified samples. (1) Two Medicine, Wyoming, taken from Figure 2 of Hower and Mowatt (1966); K indicates a reflection of kaolinite. (2) Calculated pattern for the Two Medicine sample using data obtained from the diagram of Figure 4. (3) Kinnkulle A-2, Sweden, taken from Figure 2 of Hower and Mowatt (1966). (4) Calculated pattern for the Kinnkulle A-2 sample using data obtained from the diagram of Figure 4.

tion only affects the intensities of reflections and has no influence on the  $d$ -values of reflections. If the values of  $\Delta 2\theta_1$  and  $\Delta 2\theta_2$  of a sample plot above the dotted line, the layer types in the sample are segregated, and if the values of  $\Delta 2\theta_1$  and  $\Delta 2\theta_2$  plot below the  $P_{ss} = 0.0$  line, the interstratification cannot be quantified using this diagram. Such a sample must contain three or more kinds of layers, or it should be treated as a sample for which the Reichweite value is greater than 4. XRD patterns of interstratified structures were calculated using an  $N$  value of 20. If crystallites are thin, the XRD peaks will shift from their normal positions. A value of 16.9 Å was used for the ethylene glycolated smectite layer as has been used by previous workers. Środoń (1980), however, reported a range of 16.6–17.2 Å for ethylene glycol-treated smectite. Some errors may be expected because of this simplification.

#### ACKNOWLEDGMENTS

This study was supported in part by a Grant-in-Aid for Scientific Research from the Ministry of Education, Science and Culture, Japan. The authors thank R. C. Reynolds and J. Środoń for many valuable comments and critical review of the manuscript. F. A. Mumpton kindly improved the English of this manuscript.

#### REFERENCES

- Allegra, G. (1964) The calculation of the intensity of X-rays diffracted by monodimensionally disordered structures: *Acta Crystallogr.* **17**, 579–586.
- Cradwick, P. D. (1975) On the calculation of one-dimensional X-ray scattering from interstratified material: *Clay Miner.* **10**, 347–356.
- Drits, V. A. and Sakharov, B. A. (1976) *X-ray Structure Analysis of Mixed-Layer Minerals*: Academy of Sciences, U.S.S.R., Moscow, 256 pp. (in Russian).
- Hower, J. and Mowatt, T. C. (1966) The mineralogy of illites and mixed-layer illite-montmorillonites: *Amer. Mineral.* **51**, 825–854.
- Kakinoki, J. and Komura, Y. (1952) Intensity of X-ray diffraction by a one-dimensionally disordered crystal. I. General derivation in cases of the "Reichweite"  $S=0$  and 1: *J. Phys. Soc. Japan* **7**, 30–35.
- Kakinoki, J. and Komura, Y. (1954a) Intensity of X-ray diffraction by a one-dimensionally disordered crystal. II. General derivation in the case of the correlation range  $S \geq 2$ : *J. Phys. Soc. Japan* **9**, 169–176.
- Kakinoki, J. and Komura, Y. (1954b) Intensity of X-ray diffraction by a one-dimensionally disordered crystal. III. The close-packed structure: *J. Phys. Soc. Japan* **9**, 177–183.
- Kakinoki, J. and Komura, Y. (1965) Diffraction by a one-dimensionally disordered crystal. I. The intensity equation: *Acta Crystallogr.* **17**, 579–586.
- MacEwan, D. M. C. (1958) Fourier transform methods for studying X-ray scattering from lamellar systems. II. The calculation of X-ray diffraction effects for various types of interstratification: *Kolloid-Zeitschrift* **156**, 61–67.
- Méring, J. (1949) L'Interférence des rayons-X dans les systèmes à stratification désordonnée: *Acta Crystallogr.* **2**, 371–377.
- Reynolds, R. C. (1967) Interstratified clay systems: Calculation of the total one-dimensional diffraction function: *Amer. Mineral.* **52**, 661–672.
- Reynolds, R. C. (1980) Interstratified clay minerals: in *Crystal Structures of Clay Minerals and Their X-Ray Identification*, G. W. Brindley and G. Brown, eds., Mineralogical Society, London, 249–303.
- Reynolds, R. C. (1983) Calculation of absolute diffraction intensities for mixed-layered clays: *Clays & Clay Minerals* **31**, 233–234.
- Reynolds, R. C. and Hower, J. (1970) The nature of interlayering in mixed-layer illite-montmorillonite: *Clays & Clay Minerals* **18**, 25–36.
- Sato, M. (1969) Interstratified structures: *Z. Kristallogr.* **129**, 388–395.
- Sato, M. (1973) X-ray analysis of interstratified structure: *Nendo Kagaku (J. Clay Soc. Japan)* **13**, 39–47.
- Sato, M., Oinuma, K., and Kobayashi, K. (1965) Interstratified minerals of illite and montmorillonite: *Nature* **208**, 179–180.
- Środoń, J. (1980) Precise identification of illite/smectite interstratifications by X-ray powder diffraction: *Clays & Clay Minerals* **28**, 401–411.
- Takahashi, H. (1982) Electronic computer's program for calculation of diffraction intensity by close-packed structures with stacking faults: *Bull. Fac. Educ. Kagoshima Univ.* **34**, 1–14 (in Japanese).
- Tomita, K. and Takahashi, H. (1985) Curves for the quantification of mica/smectite and chlorite/smectite interstratifications by X-ray powder diffraction: *Clays & Clay Minerals* **33**, 379–390.
- Watanabe, T. (1981) Identification of illite-montmorillonite interstratifications by X-ray powder diffraction: *J. Mineral. Soc. Japan* **15**, 32–41 (in Japanese with English abstract).

(Received 28 May 1986; accepted 6 November 1987; Ms. 1592)